



Cat® CB44B

TANDEM VIBRATORY ROLLER

Top Features

The Cat® CB44B is a 7.5 ton roller with 1500 mm (59") tandem vibratory drums. It is available in solid or split drum models and excels on a variety of asphalt mix designs as well as other granular materials.

- **Exceptional Visibility and Control** with handwheel steering technology, touch-pad machine functions, ECO-mode operation, and automatic speed control. This machine can be equipped with a Cab or ROPS/FOPS.
- **Smooth Operating Powertrain** with C3.4B engine that meets U.S. EPA Tier 4 Interim and E.U. Stage IIIB emissions standards. The split drum or solid drum designs provide the contractor with options to meet paving requirements. The split drum delivers superior mat quality and smooth performance when turning.
- **Versatile Vibratory Systems** include choice of dual amplitude/dual frequency or 5-amplitude systems. Versatile systems for both thick and thin lifts as well as varying paving speeds.
- **Cat® Compaction Control** keeps the operator informed for higher performance and efficiency. Infrared temperature sensors combined with mapping keep the operator informed of when optimal temperatures exist and where compaction has taken place. Temperature Mapping records data for analysis, while Pass-Count Mapping keeps the operator informed of where mat coverage has taken place and the number of passes made.
- **Industry-Leading Water Spray System** features a single fill point, dual water pumps, triple filtration, intermittent operation and high capacity for optimal performance. An optional freeze protection kit offers protection in cold temperatures.
- **Best Lifetime Value** with ECO-mode operation that conserves fuel, while oil-bath lubrication extends vibratory drum service intervals and minimizes life-time operating costs.

Specifications

Weights

Operating Weight – Split Drum w/ROPS/FOPS/CAB

Standard machine	9330 kg	20,569 lb
Maximum machine	10 470 kg	23,082 lb
Static linear load	31.1 kg/cm	174 lb/in

Operating Weight – Solid Drum w/ROPS/FOPS/CAB

Standard machine	8190 kg	18,056 lb
Maximum machine	8940 kg	19,709 lb
Static linear load	26.9 kg/cm	151 lb/in

Operating Weight – Split Drum w/ROPS/FOPS/CANOPY

Standard machine	9030 kg	19,908 lb
Maximum machine	10 250 kg	22,597 lb
Static linear load	29.8 kg/cm	167 lb/in

Operating Weight – Solid Drum w/ROPS/FOPS/CANOPY

Standard machine	7990 kg	17,615 lb
Maximum machine	8720 kg	19,224 lb
Static linear load	26.3 kg	147 lb/in

Service Refill Capacities

Fuel Tank	208 L	55 gal
Fuel Usage (50% duty)	12 hours	
Cooling System	18 L	4.7 gal
Engine Oil	9 L	2.4 gal
Hydraulic Tank	36 L	9.5 gal
Water Tank	742 L	196 gal

Engine – Powertrain

Engine Model	Cat® C3.4B	
Number of Cylinders	4	
Rated Speed	2200 rpm	
Bore	99 mm	3.89"
Stroke	110 mm	4.33"
Gross Power:		
Tier 4 Interim, Stage IIIB	75 kW	100 hp (l), 102 hp (m)
Speed Ranges:		
Low	0 - 7 km/hr	4.3 mph
High	0 - 12 km/hr	7.5 mph
Gradeability (no vibs):		
Solid drum	35°	
Split drum	38°	
Steering (Inside)	4.4 m	(14' 8")
Articulation Angle	35°	



CB44B Tandem Vibratory Roller

Dimensions

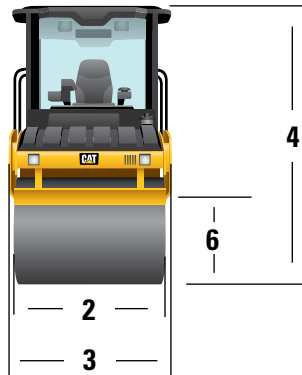
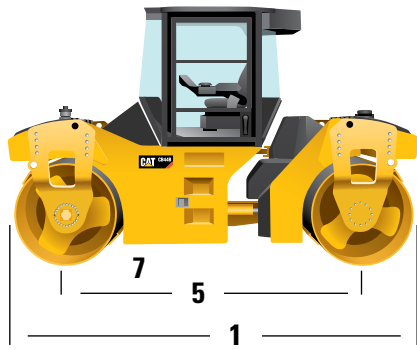

1 Overall Length	4565 mm	14' 5"
2 Drum Width	1500 mm	59"
Drum Offset	170 mm	6"
Drum Shell Thickness	16 mm	0.67"
Drum Diameter	1108 mm	44"
3 Overall width	1670 mm	5' 5"
4 Height at ROPS/FOPS	2980 mm	9' 9"
Height at Cab	2980 mm	9' 9"
5 Wheelbase	3300 mm	10' 10"
6 Curb Clearance	898 mm	35"
7 Ground Clearance	226 mm	9"

Vibratory Systems

Dual Amplitude, Dual Frequency - Split Drum

Frequency – Hz (vpm)	42/53.3	(2520/3200)
Amplitude – mm (in)	0.62 - 0.31	(0.024 - 0.012)

Dual Amplitude, Dual Frequency - Solid Drum

Frequency – Hz (vpm)	53.3/63.3	(3200/3800)
Amplitude – mm (in)	0.65 - 0.31	(0.026 - 0.012)

Dual Amplitude, Dual Frequency - Solid Drum

Frequency – Hz (vpm)	45/53.3/57	(2700/3200/3420)
Amplitude – mm (in)	0.65 - 0.31	(0.026 - 0.012)

Five amplitude - Solid Drum

Frequency – Hz (vpm)	53.3	(3200)
Amplitude – mm (in)	high	0.64 (0.025)
	medium high	0.56 (0.022)
	medium	0.45 (0.018)
	medium low	0.35 (0.014)
	low	0.25 (0.010)

Standard and Optional Equipment

STANDARD EQUIPMENT:

- Front and Rear Solid Drums
- 5-Amplitude Vibratory System
- Sealed Pod Vibratory System
- ROPS/FOPS Platform
- Two-Speed Hydrostatic Transmission
- Locking Engine Compartment
- Triple Filtered Water Spray System
- 742 L Water Tank Capacity
- 12-Volt Electrical System
- 120 Amp Alternator
- Suspension Seat
- Working Lights

OPTIONAL EQUIPMENT:

- ROPS/FOPS Cab
- Roading Lights
- Air Conditioning
- Bio-Degradable Oil
- Freeze Protection Kit
- Mirrors
- Warning Beacon
- Water Distribution Mats (cocoa)
- Water Distribution Mats (rubber)
- Product Link
- Recording Module (cab only)
- Edge Cutter
- Chip Spreader Ready (split drum)
- Air Suspension Seat w/Heat
- High Ambient Cooling System
- Temperature Gauge
- Cat Compaction Control (Temperature and Pass-Count Mapping)
- Halogen Lights w/Drum Edge Lights
- High Intensity Discharge (HID) w/ Drum Edge Lighting
- Temperature Gauge (single sensor)
- Front and Rear Split Drum

For more complete information on Cat products, dealer services, and industry solutions, visit us on the web at www.cat.com

QEHQ1584-01 (09-12)

© 2012 Caterpillar
All Rights Reserved

Materials and specifications are subject to change without notice. Featured machines in photos may include additional equipment. See your Cat dealer for available options.

CAT, CATERPILLAR, SAFETY.CAT.COM, their respective logos, "Caterpillar Yellow" and the "Power Edge" trade dress, as well as corporate and product identity used herein, are trademarks of Caterpillar and may not be used without permission.

